

INSTRUCTION FOR PRESSURE BALANCE VALVE

MODE NUMBER: JL04BD

DESCRIPTION :

JL04BD is 40mm Pressure Balance Valve, Low Torque Structure Type with distributor.

FUNCTION :

1. The angle of spindle from close to fully open is 25°. The rotary direction of the cold water is counter clockwise with 0°~55°. On the contrary, the rotary direction of hot water is clockwise with 0°~55° (Fig 2)
2. The Pressure Balance Valve was designed to be adjusted incoming hot or cold water pressure and compensates for fluctuations to keep shower outlet water temperature constant and comfortable, avoiding scald.

INSTALLATION:

1. Make sure the proper position of the hot/cold water supply pipes before installing the valve.
2. When face to hot/cold water supply pipes, the right side is cold water supply and the left side is hot water supply. Fit two set points on the bottom of the valve into the bores of faucet body, and then fasten both of them with nut. (Fig 1)
3. The nut lock torque suggested: 100kgf.cm to 120 kgf.cm.
4. The hot/ cold water supply condition:
Hot water supply 48.9°C (120°F) – 82°C (180°F).
Cold water supply 3.9°C (39°F) – 26.7°C (80°F).
5. Recommended Water Pressure (Max.): 500 PSI.
6. When finish assembly, make sure it is cold water, warm water, hot water incoming when you turn on the faucet.
7. The valve must be set by professional installer to ensure its safety. Any improper installation will raise the discharge temperature and may get hot burns.

NOTICE:

1. If the water contains heavy contaminants, it should be checked frequently to ensure the device is working properly. The inspect times depend on the amount of contaminants in the water.
2. The balance valve must be installed by professional technicians to ensure safety. Any improper installation will cause discharge temp. and may get burns.

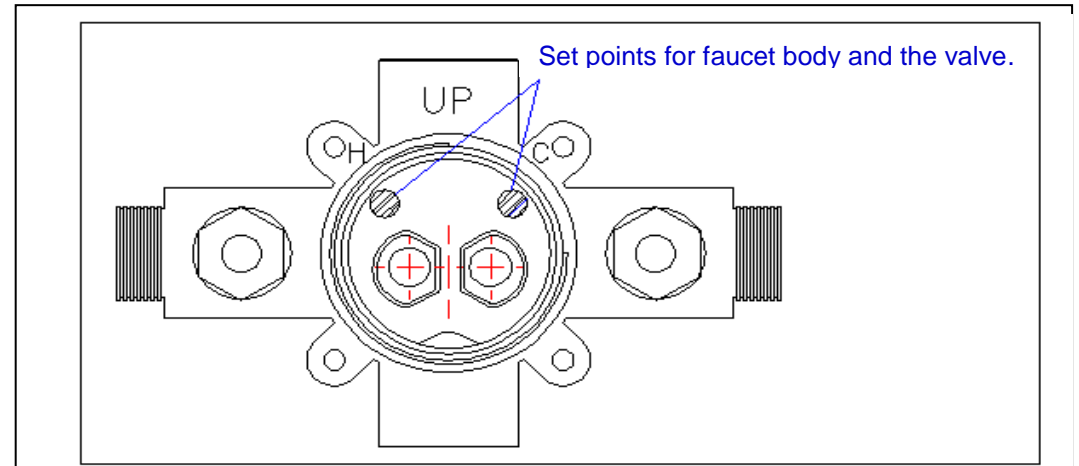

(Fig 1)

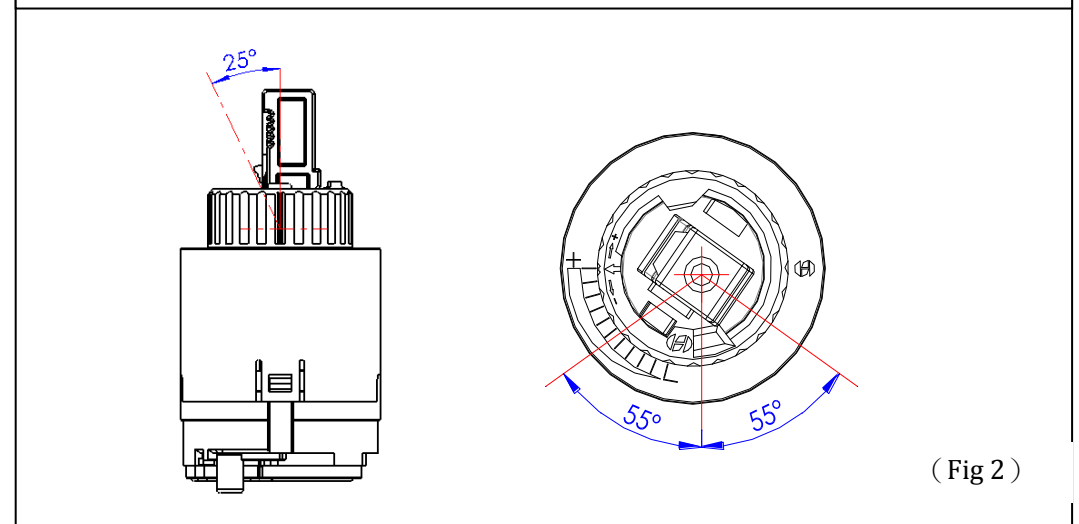

(Fig 2)